

Baton series 'E500' Euro Mortise Door Lock Case is designed for accommodating a Lever/Lever style trim. The mortise case takes any standard Euro Profile Cylinders.

The 7" high mortise case is constructed with one 7/8" single throw investment casting solid stainless steel deadbolt, one non-handed field reversible spring latch, and one auxiliary latch to add extra security. All exposed Bolts are made of stainless steel (S).

Mounting hardware, dust box and one 1-1/4" wide non-handed strike (EZ-S3CU) are furnished as standard.

Finishes : US32D Hub size: 8mm on square.
Backset : 2-3/8" (60mm)

According to EN 12209:2003, the locks are classified as: **2C400B3HA10**

The lock fulfills the safety relevant characteristics of Class 3 as per DIN 18251 and EN 179.

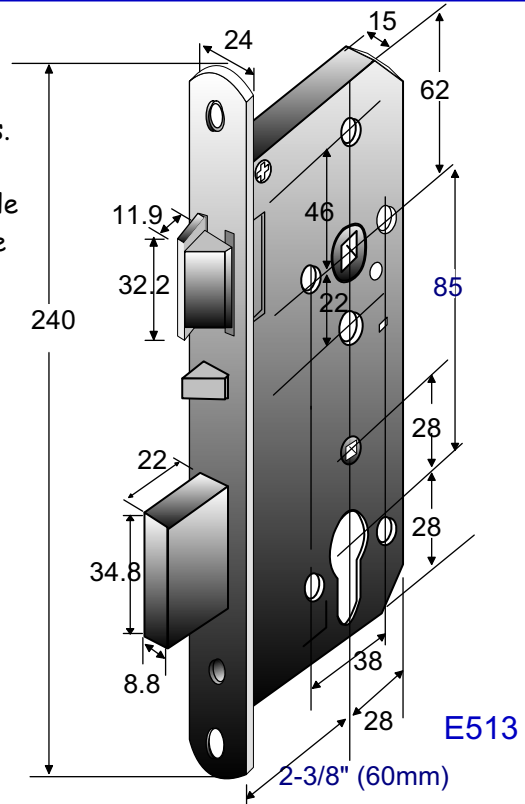
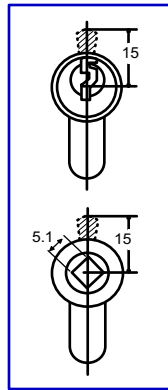

E06a

Model No.	Backset	Function	Depiction
E501LL8S60	2-3/8" (60mm)	Passage Latch by Lever from either side.	
E508LL8S60	2-3/8" (60mm)	Entrance (without egress) Latch by Lever from either side. Deadbolt by Cylinder either side. Continue to turn the Cylinder operates the Latch. Auxiliary Latch deadlocks the Latch.	
E513LL8S60	2-3/8" (60mm)	Entrance (with egress) Latch by Lever from either side. Deadbolt by Cylinder either side. Inside Lever retracts Latch and Deadbolt simultaneously. Auxiliary Latch deadlocks the Latch.	
E517LL8S60	2-3/8" (60mm)	Deadlock Deadbolt by Cylinder either side.	